



Краткая инструкция

Шлагбаум

MHTM™ MicroDrive

Access, Parking, Toll

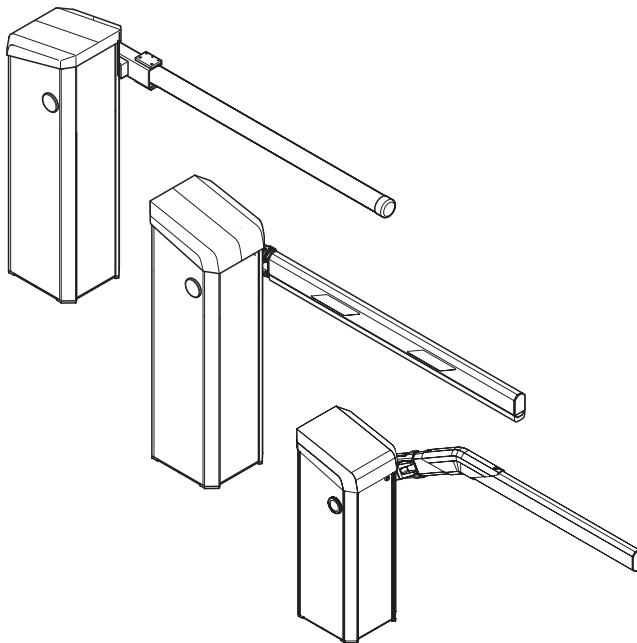

Access Pro H
Access
Access Pro
Parking
Parking Pro

Toll
Toll Pro
Toll Pro 2
Toll HighSpeed
Toll HighSpeed 2





Access, Parking, Toll

Краткая инструкция

Содержание

1	Безопасность	3
2	Комплект поставки.....	3
2.1	Access Pro H	3
2.2	«Access» и «Parking»	4
2.3	Toll.....	4
3	Необходимые инструменты	5
4	Размеры	6
4.1	Access Pro H	6
4.2	«Access» и «Parking»	7
4.3	Toll.....	8
5	Изготовление фундамента и монтаж корпуса	9
6	Удалить транспортировочное крепление	10
7	Электрическое подключение	10
8	Монтаж стрелы шлагбаума.....	11
8.1	Access Pro H	11
8.2	«Access» и «Parking»	13
8.3	Toll.....	16
9	Выравнивание стрелы шлагбаума	17
10	Установить компенсационные пружины.....	18
11	Наклеить предупредительные таблички.....	18
12	Введение шлагбаума в эксплуатацию	19





Access, Parking, Toll
Краткая инструкция

2.2 «Access» и «Parking»

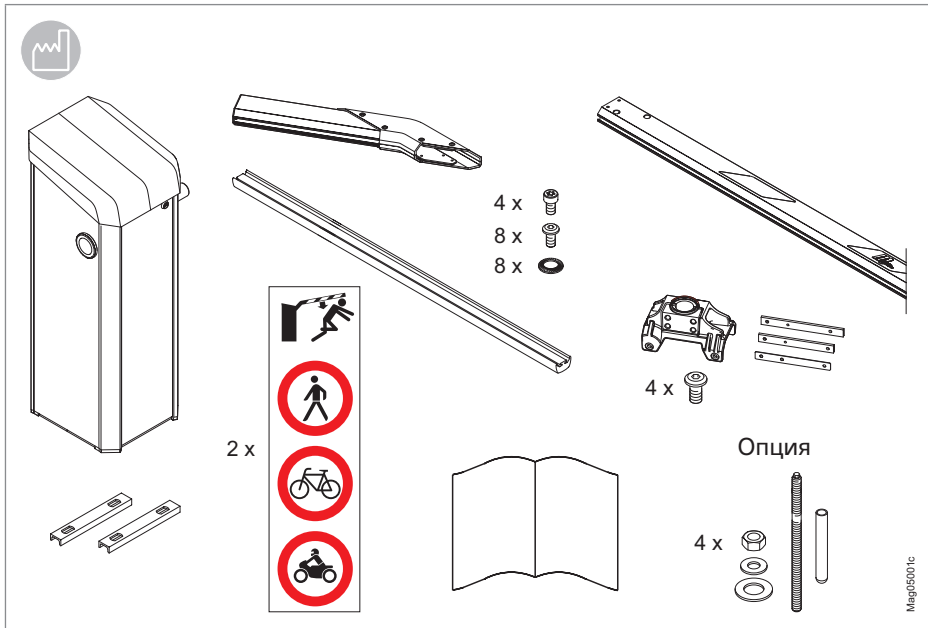



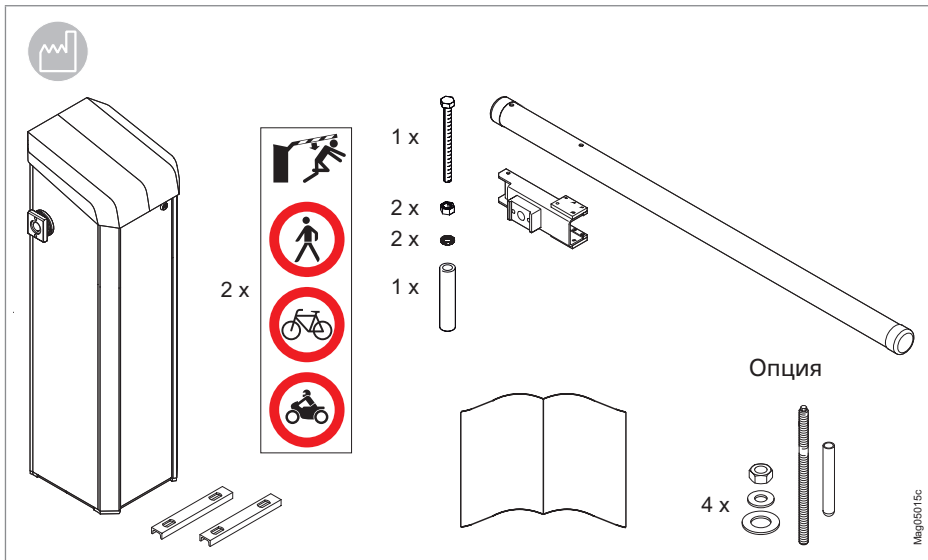



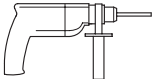
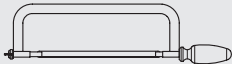
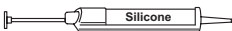

2.3 Toll



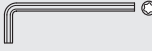

3 Необходимые инструменты

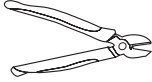
		Access Pro H	Access / Parking	Toll
	Перфоратор 10 mm	x	x	x
	Пила	x	x	-
	Картридж с силиконом	x	x	x
	Гаечный ключ 13 мм	x	x	x
	динамометрический ключ: Ключ "звездочка" T40	x	x	-
	динамометрический ключ: внутренним шестигранником SW 8	-	-	x
	динамометрический ключ: внутренним шестигранником SW 10	x	x	-
	Звездобразный ключ T10	x	x	x
	Звездобразный ключ T20	-	x	-
	Звездобразный ключ T30		x	-
	Крестовая отвертка 3,5 мм	x	x	-
	Бокорезы	x	x	x





Access, Parking, Toll

Краткая инструкция

4 Размеры

4.1 Access Pro H

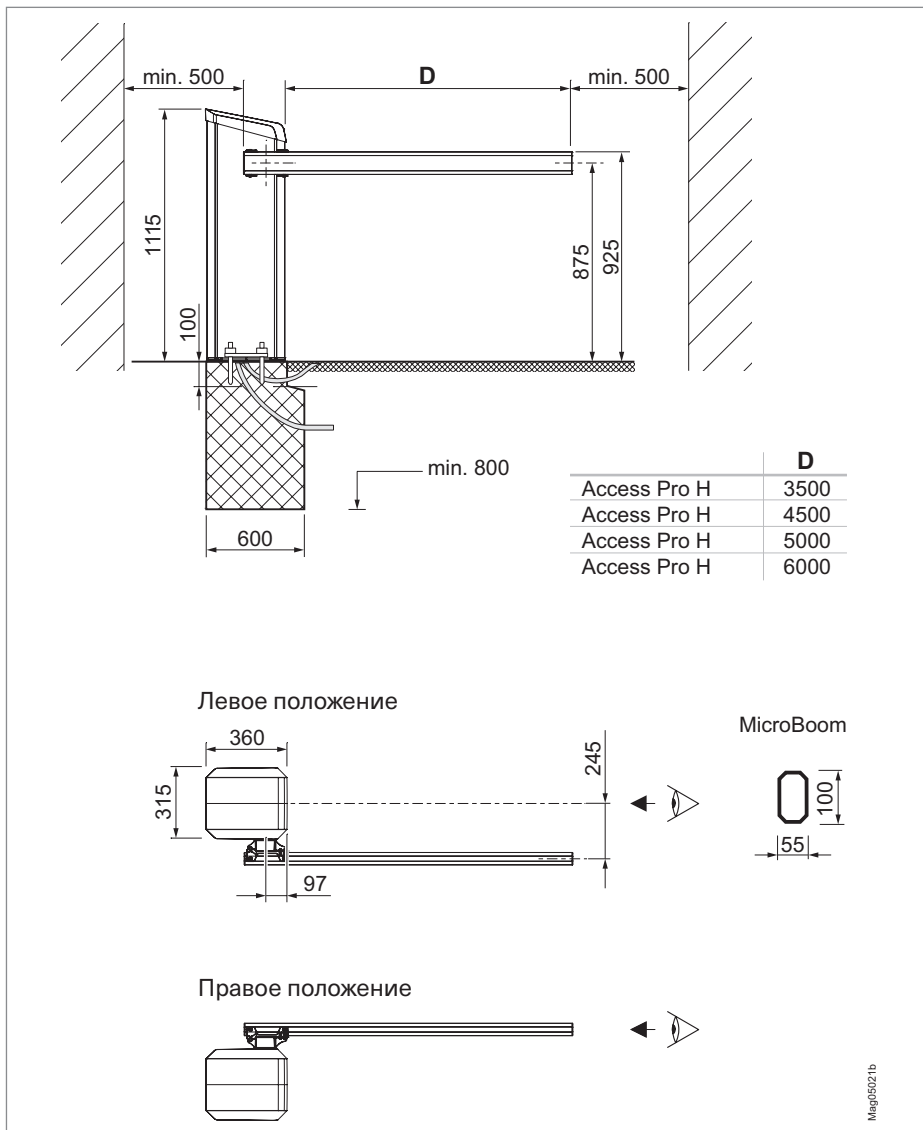



4.2 «Access» и «Parking»

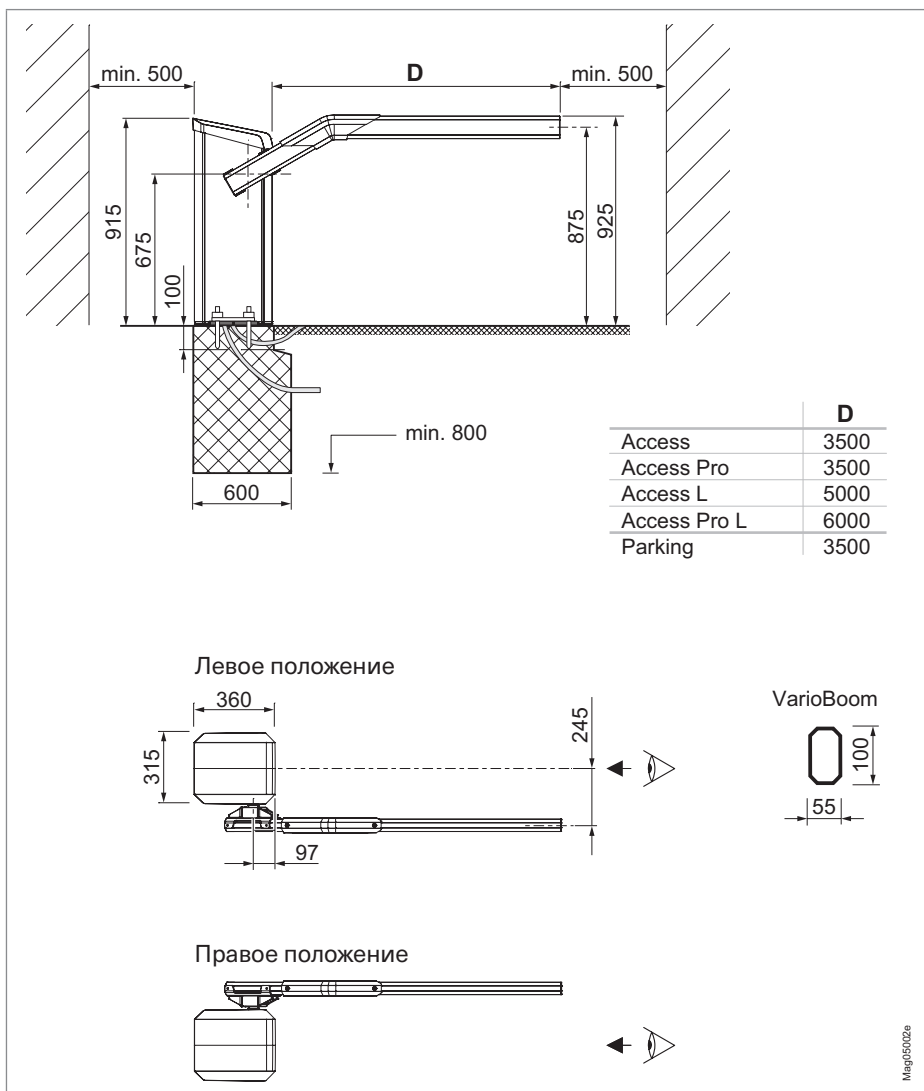



Access, Parking, Toll
Краткая инструкция

4.3 Toll

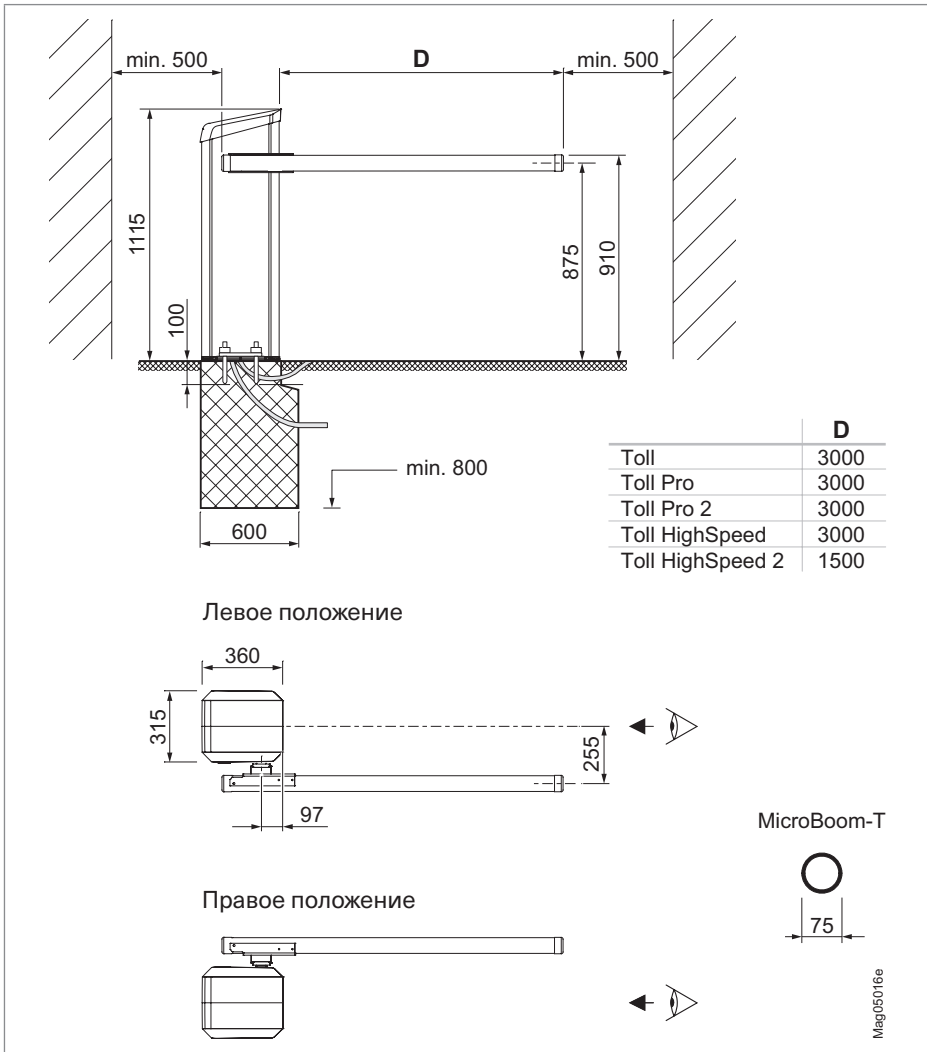



5 Изготовление фундамента и монтаж корпуса

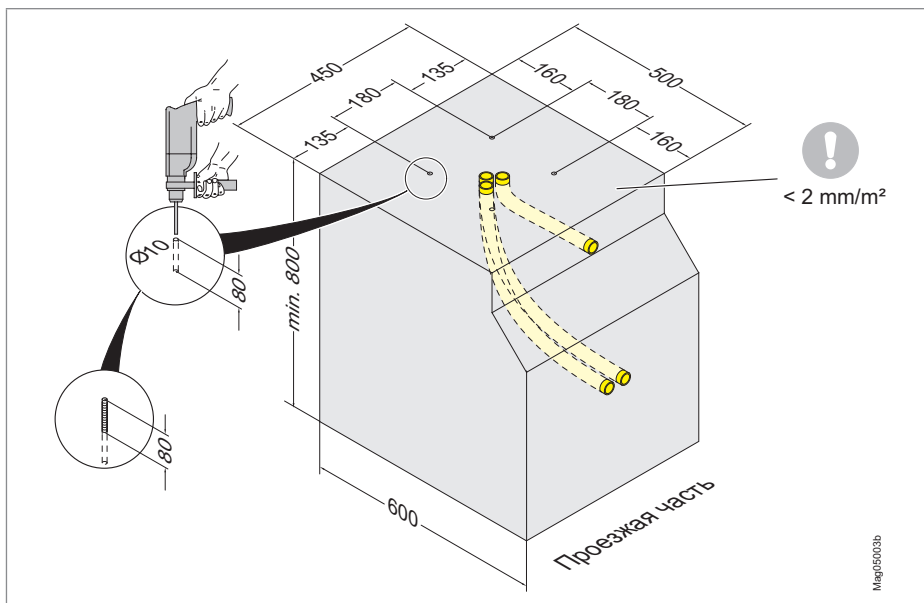

! Сведения о регулировке корпуса см. в пункте 4, начиная со страницы 6.

1

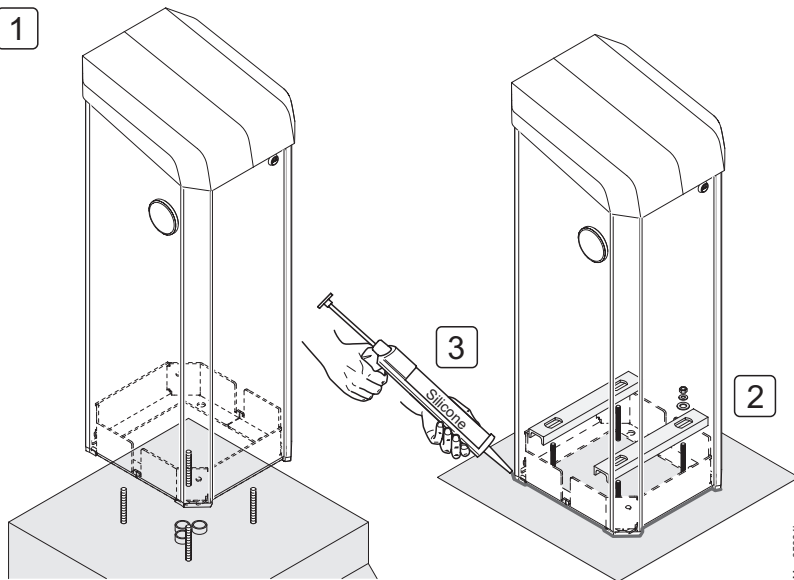



Access, Parking, Toll
Краткая инструкция

6 Удалить транспортировочное крепление

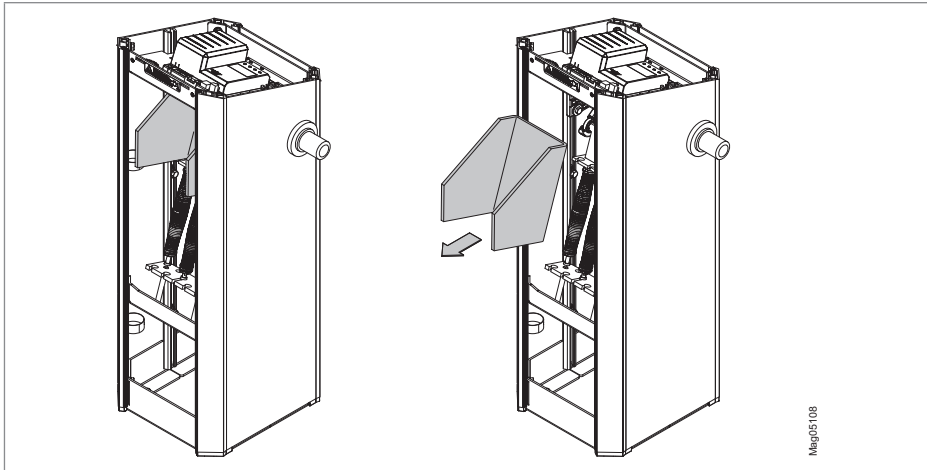

7 Электрическое подключение

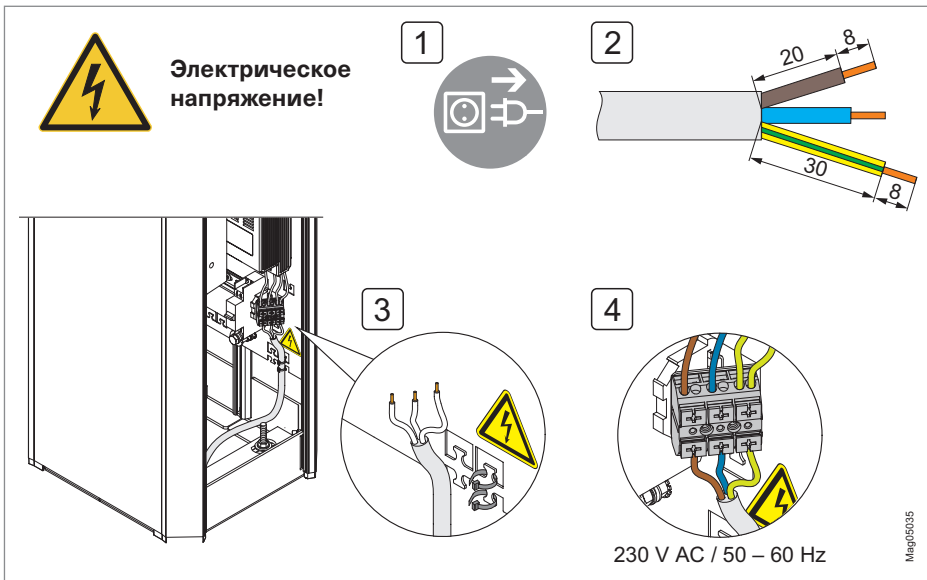



8 Монтаж стрелы шлагбаума

8.1 Access Pro H

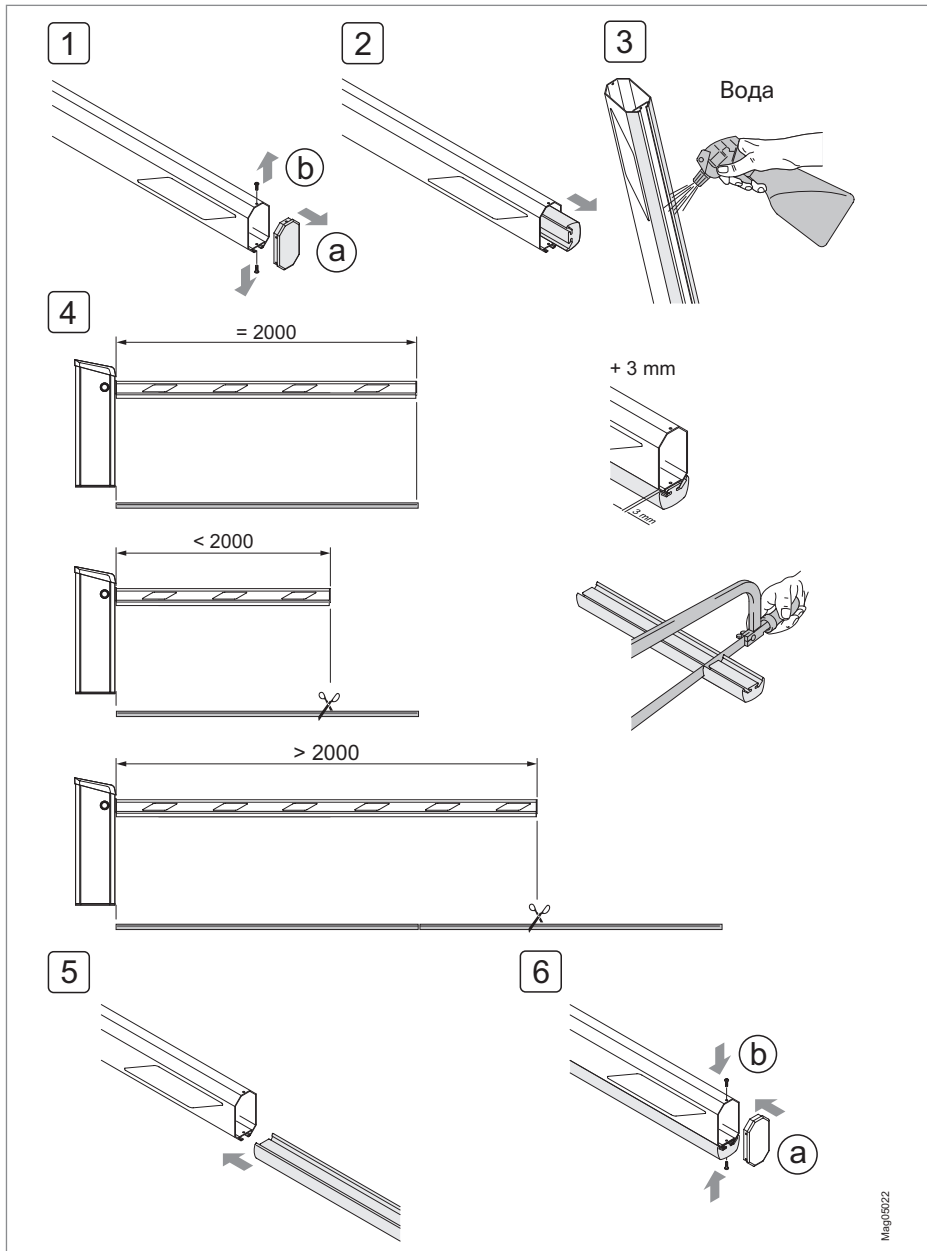



Access, Parking, Toll
Краткая инструкция

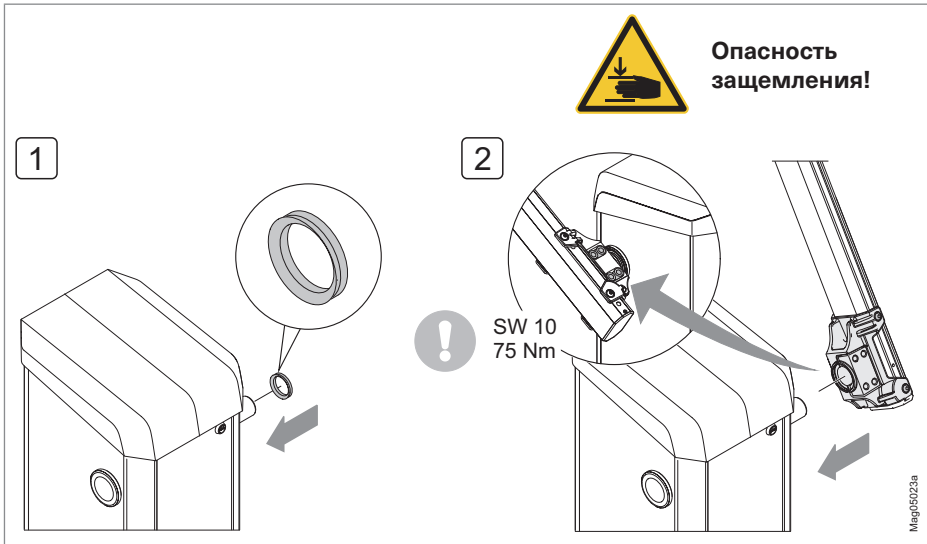
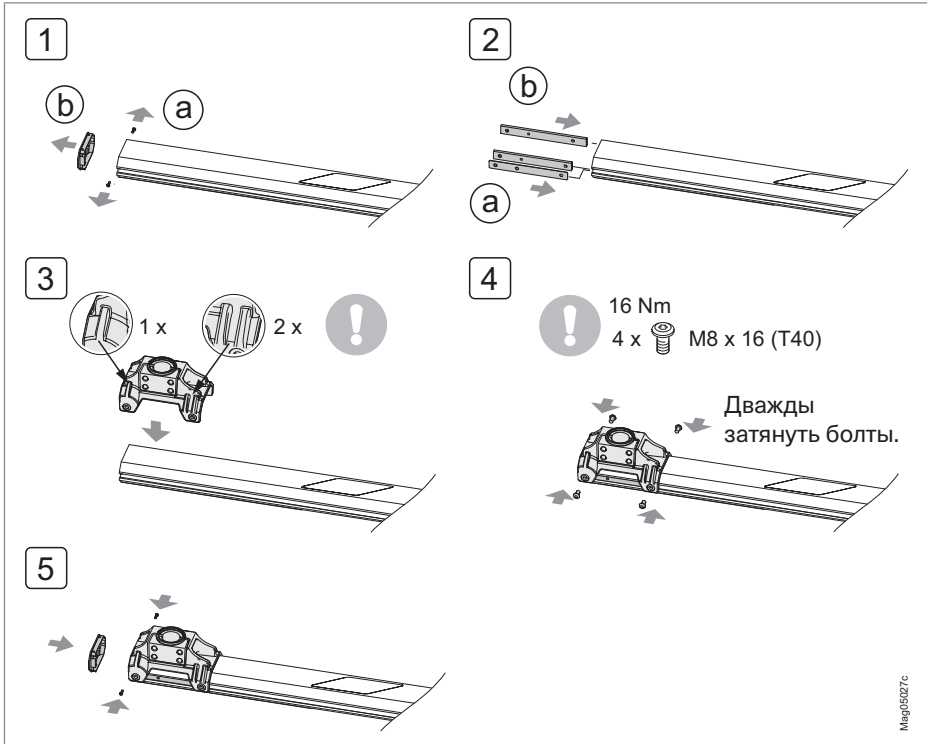



8.2 «Access» и «Parking»

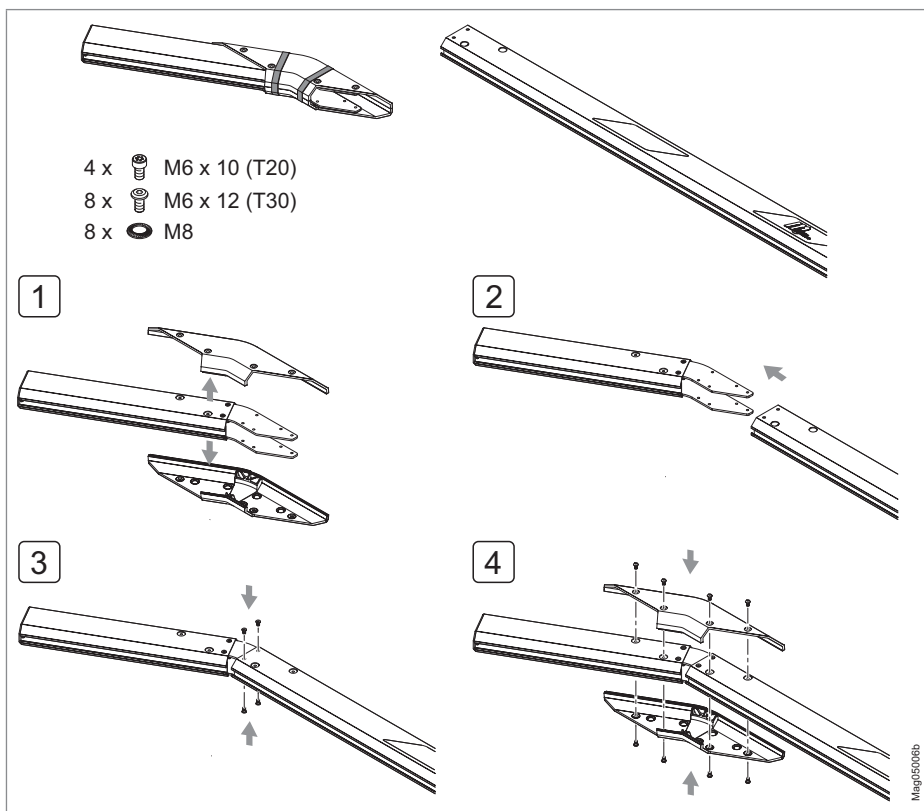



Access, Parking, Toll
Краткая инструкция

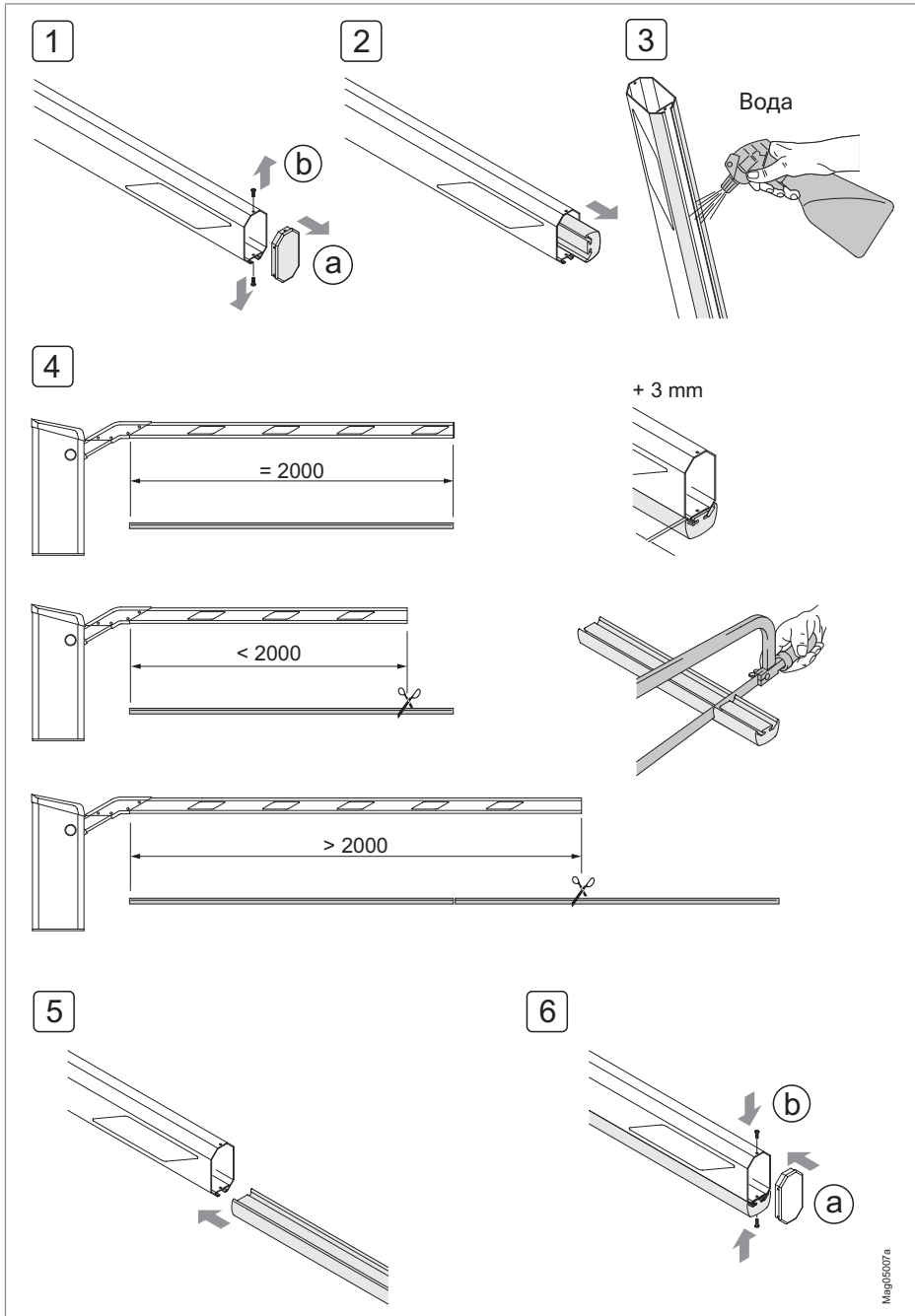



Access, Parking, Toll
Краткая инструкция

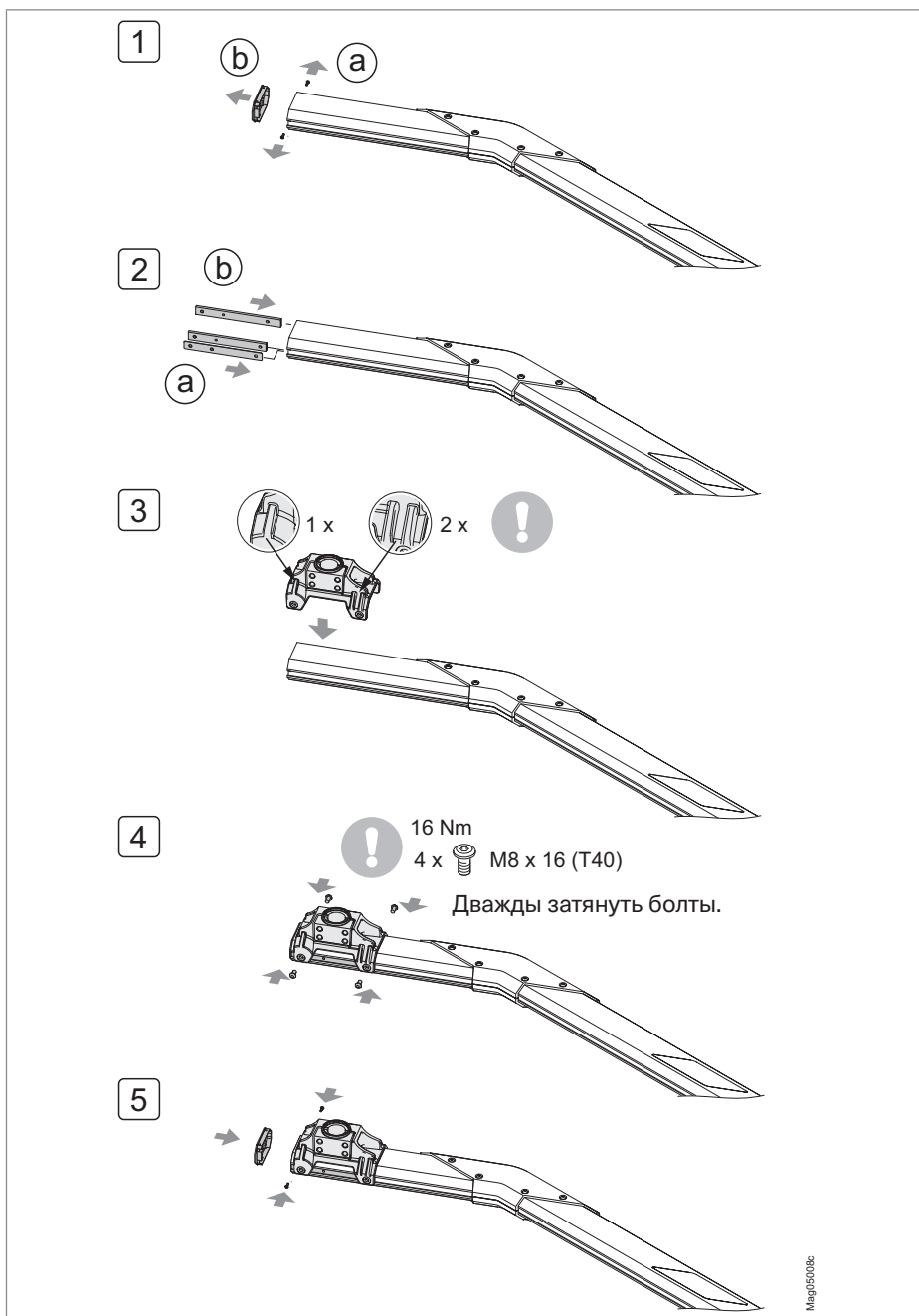



Access, Parking, Toll
Краткая инструкция

8.3 Toll

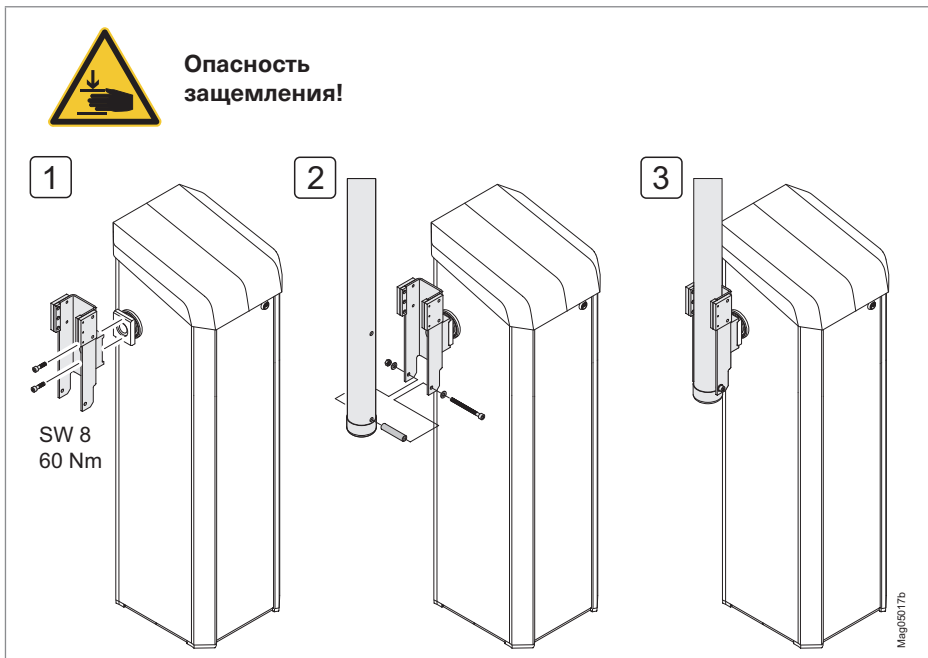
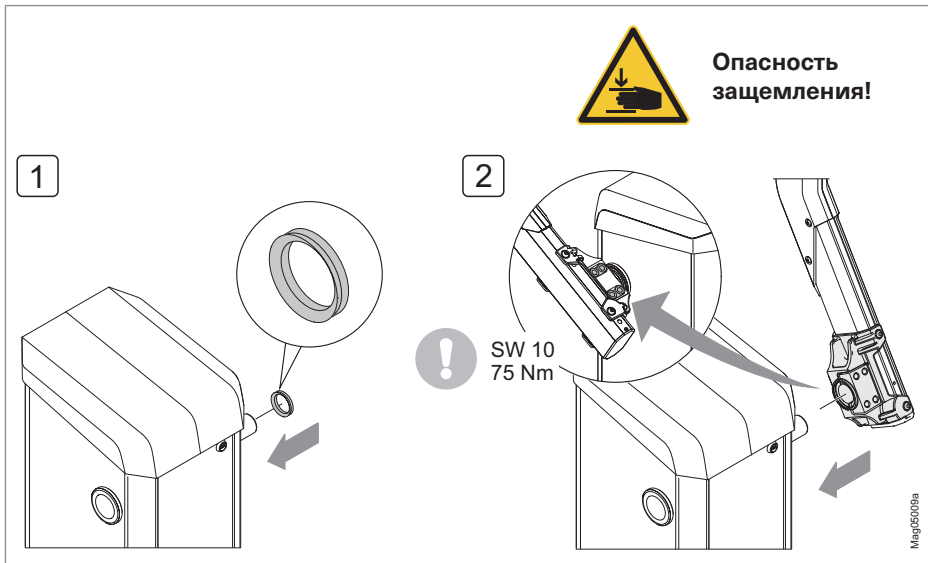



9 Выравнивание стрелы шлагбаума

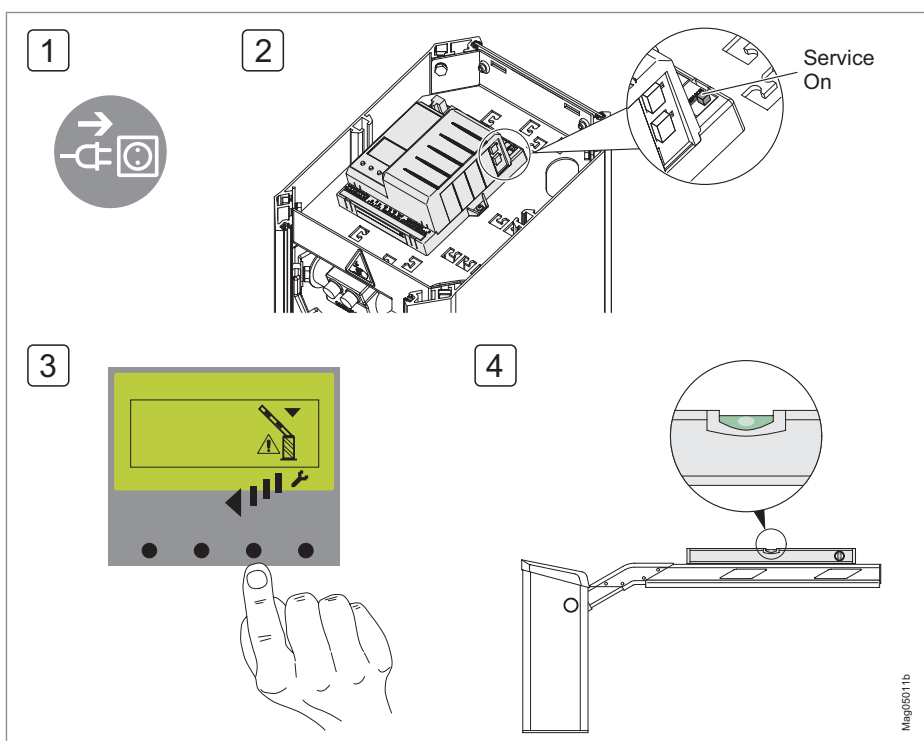



10 Установить компенсационные пружины

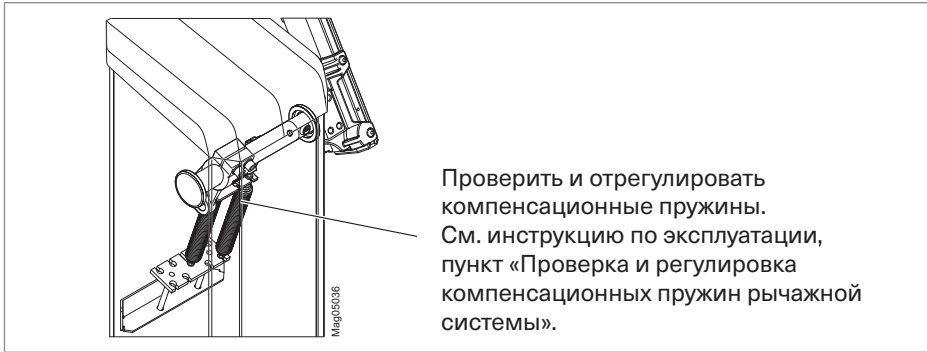

11 Наклеить предупредительные таблички

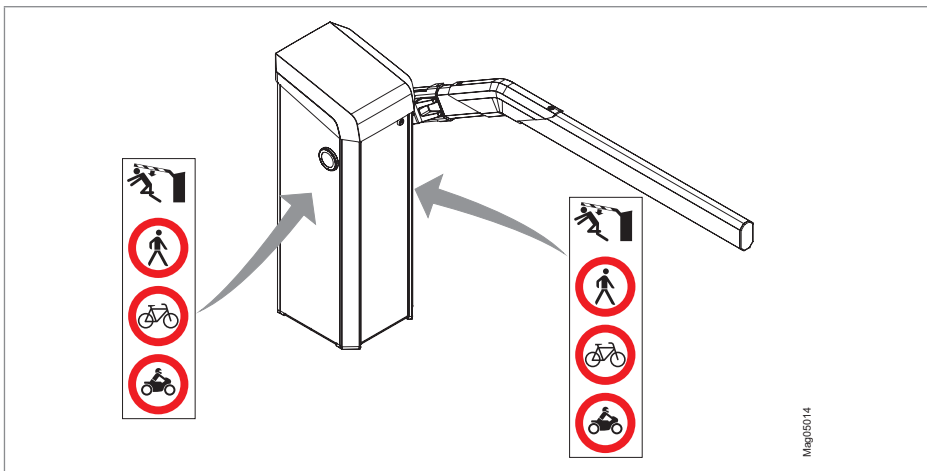



12 Введение шлагбаума в эксплуатацию

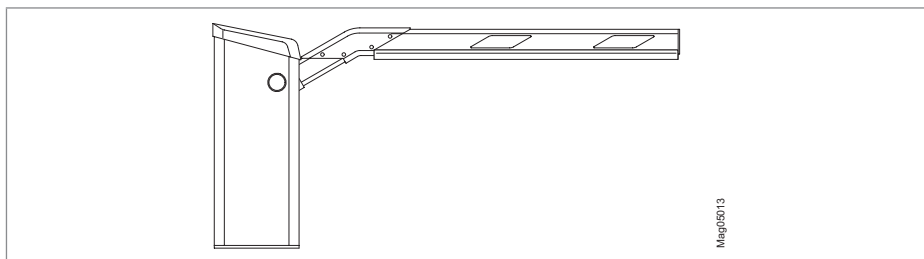
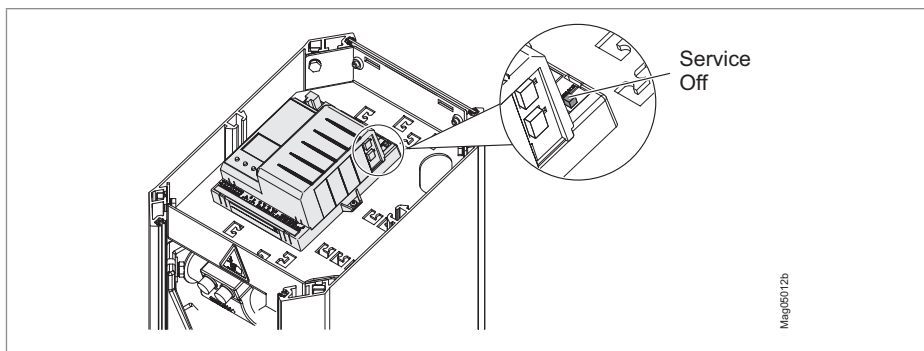



MAGNETIC AUTOCONTROL GMBH

Grienmatt 20

79650 Шопфхайм

Германия

Телефон +49 7622 695 5

Факс +49 7622 695 802

info@magnetic-germany.com

www.magnetic-access.com

Аоговорных партнеров

Doc.ID: 5816,0002RU
Версия 07

